



# **Excelelevator<sup>TM</sup> Elevator**

**Built on T-Rail**

**Series F021 MRL - 1,000 lbs.**

**Series F022 RMR - 1,000 lbs.**

1726 North Ballard Road, Suite 1 • Appleton, WI 54911

Direct Phone: 920-991-9082

Toll Free: 800-238-8739

Email: [info@foxvalleyelevator.com](mailto:info@foxvalleyelevator.com)



# Members Of:

---

Fox Valley Elevator, LLC is a proud member of The American Society of Mechanical Engineers, The National Association of Elevator Contractors, The Canadian Elevator Contractors Association and The Accessibility Equipment Manufacturers Association. These organizations are symbols assure you of our commitment to high quality and accessibility to everyone.



## Table of Contents

---

Introduction & Planning Steps.....	4
Design Features Mechanical Illustrations (Series F021).....	5
Design Features Mechanical Illustrations (Series F022).....	6
Rail and Pit Floor Reactions .....	7
Elevator Equipment.....	8
Hoistway Specifications.....	9
MRL Machinery Spaces, Machine Rooms, Control Spaces, and Control Rooms Layouts & Wiring (Series F021).....	10-11
RMR Machinery Spaces, Machine Rooms, Control Spaces, and Control Rooms Layouts & Wiring (Series F022).....	12-14
Example Hoistway Construction.....	15
Hoistway Elevation View & Rail Layout (Series F021).....	16
Hoistway Elevation View & Rail Layout (Series F022).....	17
Example Hoistway Layouts.....	18-21
Notes.....	22

# Introduction

---

This Planning Guide is to be used as a reference to determine parameters of installation and steps taken to achieve a proper elevator installation. This guide may be used by the architect, contractor, dealer or home owner. The information in this guide is intended as an overview. Each installation will have job specific specifications that must be followed. Do not attempt to construct a hoistway on this information.

Elevator installation is to be done by an authorized elevator contractor and in accordance with installation instructions provided by the manufacturer. Installation must also be in compliance with requirements of the National Electrical Code, American Society of Mechanical Engineers Safety Code, and state and local building codes. Fox Valley Elevator, LLC products are designed to meet the residential elevator requirements of ASME A17.1 Safety Code for Elevators and Escalators. The manufacturer assumes no liability for equipment not installed in compliance with these codes.

Fox Valley Elevator, LLC reserves the right to modify the design, technical specifications and dimensions of the products shown in this document.

## Planning Steps

---

Locate a local authorized dealer and custom design your elevator together. Congratulations on choosing a winding drum drive system. If you prefer a hydraulic power based elevator please locate and use the Planning Guide for Residential Hydraulic Elevators. Please complete steps below to finish creating your elevator package.

1. Select rail system.
2. Layout machine room and location.
3. Plan for electrical requirements.
4. Address national, state, and local code requirements.
5. Determine hoistway size, car size, layout configuration, and available options. Please reference a Fox Valley Elevator Brochure for available design options: cab style, car operating panels, hall stations, phone boxes, handrails, light fixtures, and gates.
6. Obtain and follow site specific field drawings. Forward all necessary documents to contractor/ builder, architect, and structural engineers. Use job specific drawings while building hoistway, doorways, machine room, and any other construction related to the elevator.
7. Coordinate with your authorized dealer to install your elevator and enjoy your custom designed elevator.

Fox Valley Elevator, LLC will be referred as Fox Valley Elevator or FVE through out the remainder of this document.

# Design Features & Mechanical Illustrations

## T-Rail System with Winding Drum Technology (Series F021)

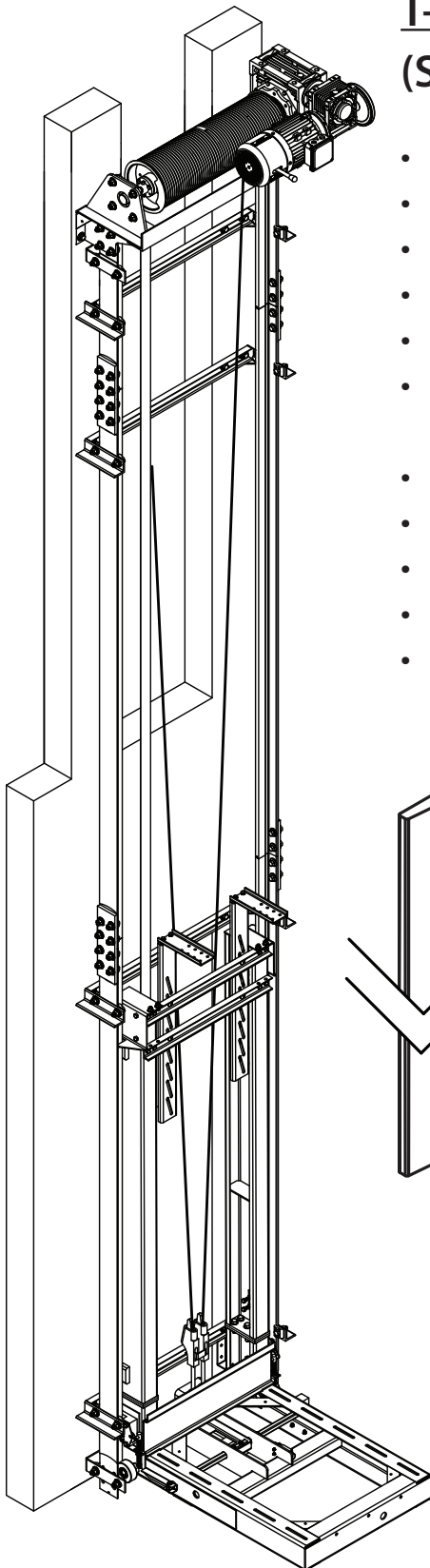

- (MRL) Machine Roomless
- Rigid Design Built on 8 lb. T Rail System
- Utilizes Proven Winding Drum Technology
- System Free of Hydraulic Oil
- Durable Cantilever Sling Design
- Sling Movement Translates Through Roller Wheels Enhancing Ride Quality
- PLC Control System with Variable Frequency Drive
- Tape Reader Locates Floors with Magnetic Sensors
- Emergency Raising and Lowering Hand Wheel is Standard
- Access Door Required by Powerhead
- Battery Back Up Lowering System is Standard

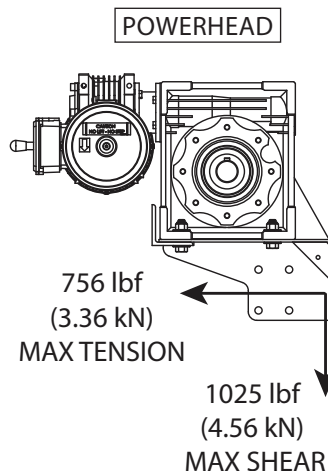

# Design Features & Mechanical Illustrations

## T-Rail System with Winding Drum Technology (Series F022)

- (RMR) Reduced Machine Room
- Rigid Design Built on 8 lb. T Rail System
- Utilizes Proven Winding Drum Technology
- System Free of Hydraulic Oil
- Durable Cantilever Sling Design
- Sling Movement Translates Through Roller Wheels Enhancing Ride Quality
- PLC Control System with Variable Frequency Drive
- Tape Reader Locates Floors with Magnetic Sensors
- Emergency Raising and Lowering Hand Wheel is Standard
- Battery Back Up Lowering System is Standard

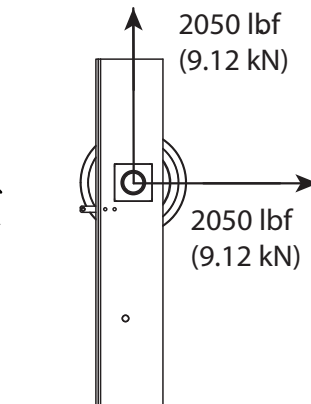
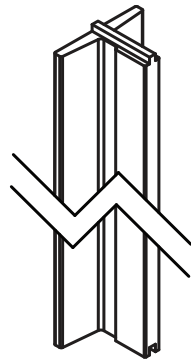
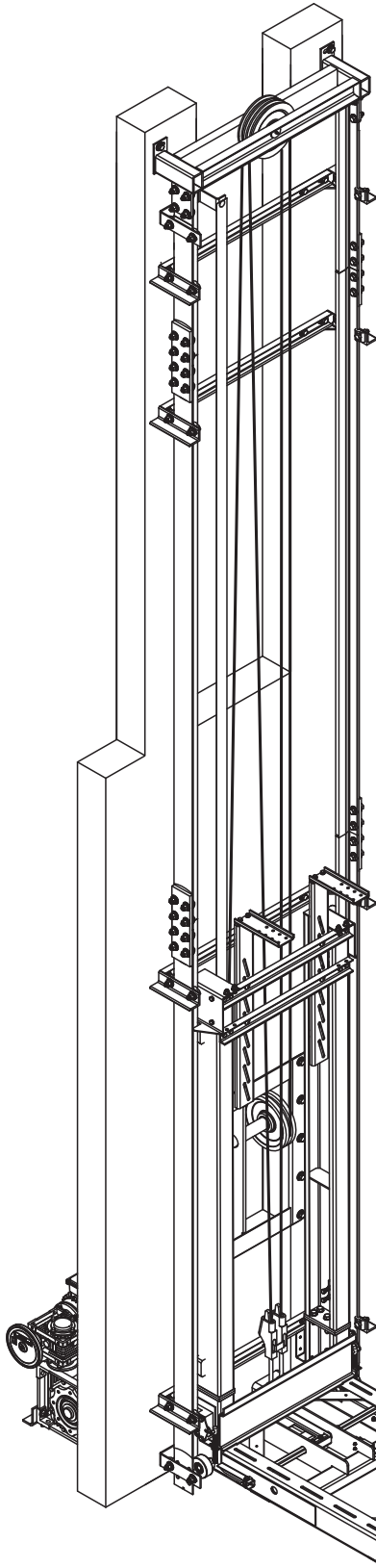

THROUGH THE WALL TRAVELING SHEAVE

TOP SHEAVE

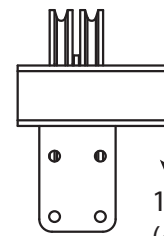

756 lbf  
(3.36 kN)  
MAX TENSION

1025 lbf  
(4.56 kN)  
MAX SHEAR



POWERHEAD

2050 lbf  
(9.12 kN)  
MAX. SHEAR

1474 lbf  
(6.56 kN)  
MAX. TENSION

**MAXIMUM LIVE (STATIC) LOAD = 1000 lbf**  
**MAXIMUM DEAD (STATIC) LOAD = 1050 lbf (SEE NOTE #3)**  
**MAXIMUM TOTAL (STATIC) LOAD = 2050 lbf**  
**MAXIMUM SHEAR (STATIC) PER BRACKET = 1025 lbf (257 lbf PER FASTENER)**  
**MAXIMUM TENSION (STATIC) PER BRACKET = 756 lbf (189 lbf PER FASTENER)**

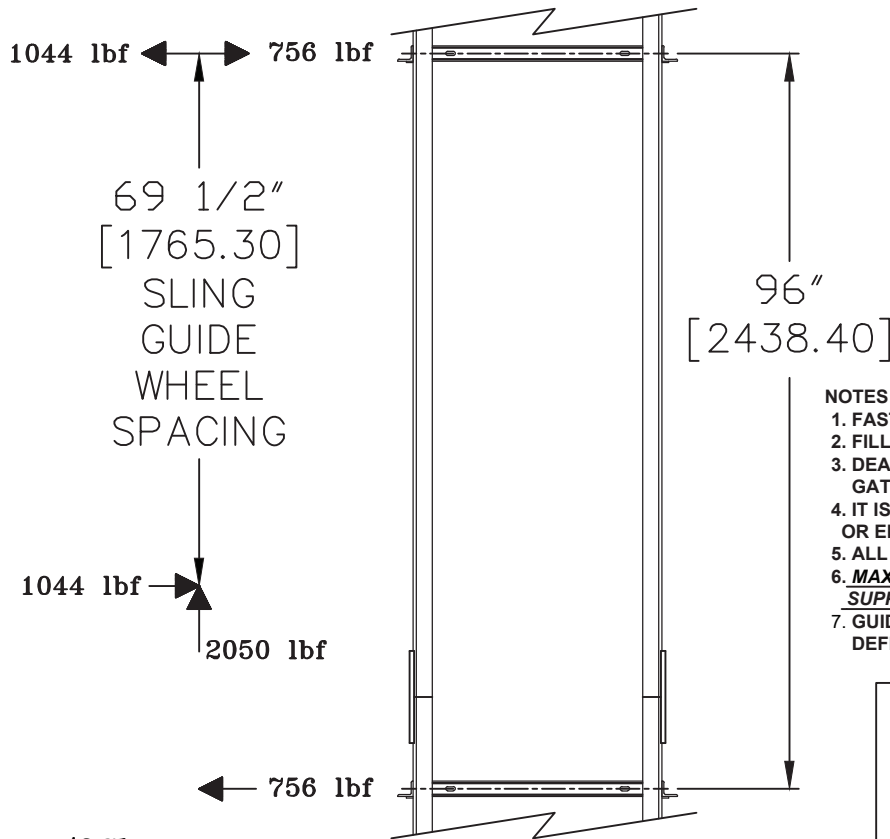

SIDE VIEW OF RAIL BRACKET

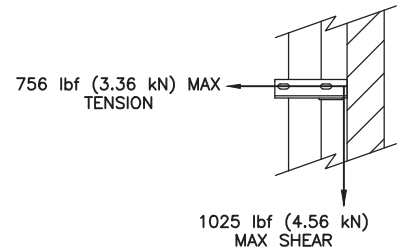

**NOTES:**

1. FASTENERS BY OTHERS.
2. FILL ALL ANCHOR POINTS.
3. DEAD LOAD OF ELEVATOR INCLUDES SLING, CAB, FLOORING GATE(S), ETC. AND ALL PERMANENT FIXTURES.
4. IT IS THE RESPONSIBILITY OF THE INSTALLER/CONTRACTOR OR ENGINEER TO DESIGN AND SPECIFY STRUCTURAL SUPPORTS.
5. ALL CONSTRUCTION TO BE IN COMPLIANCE WITH LOCAL CODES.
6. MAXIMUM RAIL BRACKET TENSION/SHEAR MOVES UP AND DOWN SUPPORT WALL AT 40 FEET PER MINUTE.
7. GUIDE RAIL SUPPORT WALL CANNOT EXCEED 1/8" OF TOTAL DEFLECTION AT POINT OF SUPPORT. (PER ASME A17.1 2.23.5.2)

**NOTE:**  
 ALL DIMENSIONS ARE IN INCHES.  
 DIMENSIONS IN [ ] ARE MM.

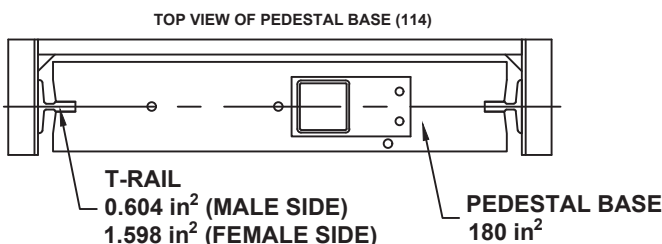
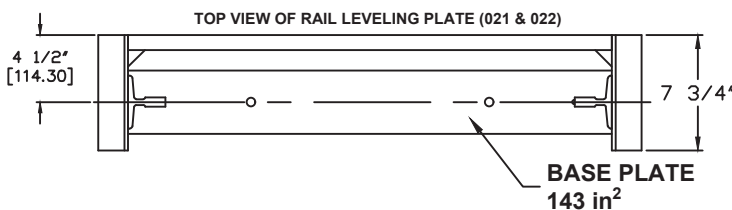
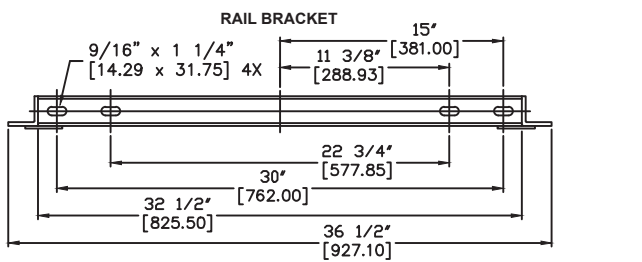

(BUFFER SPRINGS ARE PROVIDED WHEN PIT DEPTH IS 17" OR GREATER)

**BUFFER SPRING LOCATION EXCELEVATOR**

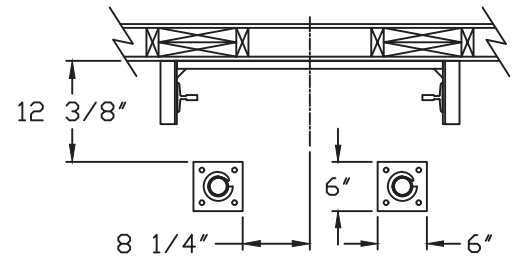

**Impact Load Per Spring (Per ASME A17.1 8.2.3.2)**

1/2 Weight of Dead and Live Load	1025 lbs
Maximum Stroke of Buffer Spring	2.71 in
Impact	2148 lbs

**FOX VALLEY ELEVATOR™**  
 1726 North Ballard Road  
 Appleton, WI 54911  
 Phone: 800-238-8739

ELEVATOR CONTRACTOR:

JOB NAME: ORDER NUMBER:

**EXCELEVATOR-SERIES RAIL AND PIT FLOOR REACTIONS**

DRAWN BY: DATE: SIGNATURE OF APPROVAL DWG. NO. C-003071

# Elevator Equipment - Series F021 & F022

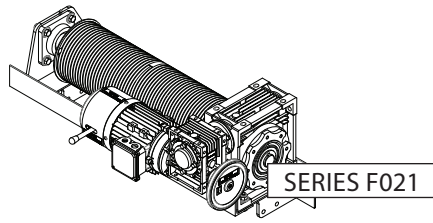

## Powerhead

The powerhead is a motor and gearbox that efficiently moves the elevator car by a positive means of wrapping a steel wire rope around a grooved drum.

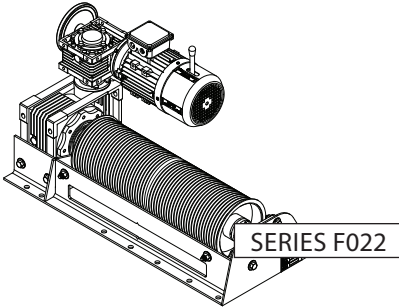

## Gearbox

Double reduction sealed gearbox combination for greater efficiency and reduced maintenance.

## Motor

230V 3-phase brake motor for efficiency, higher torque, speed control, and landing accuracy.

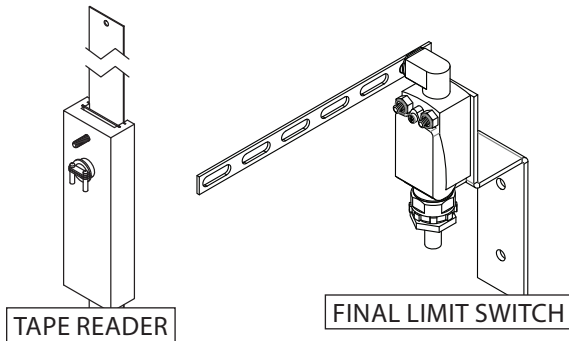

## Stopping Devices

Magnetic tape reader for leveling accuracy & final limit switches.

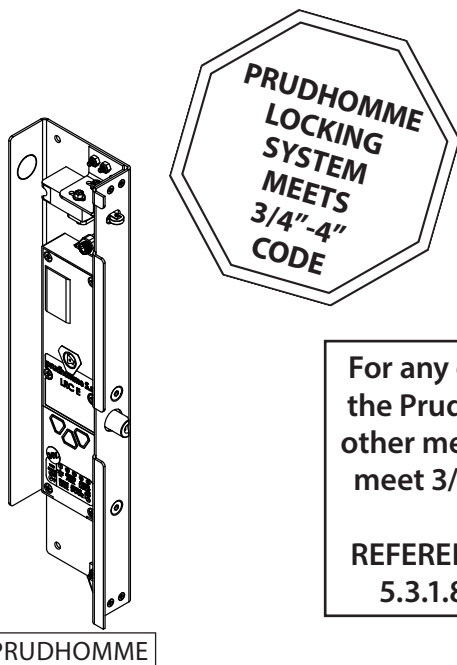

## Hoistway Door Interlocks

To prevent the opening of the hoistway door unless the car is within landing zone or stopped at landing.

For any other interlock other than the Prudhomme, a space guard or other means must be purchased to meet 3/4"-4" 2016 code or newer.

REFERENCE ASME A17.1/ CSA B44: 5.3.1.8 & 5.3.1.9 FOR DETAILS.

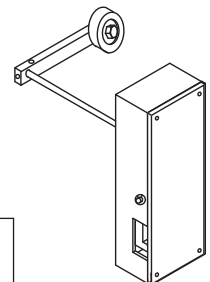
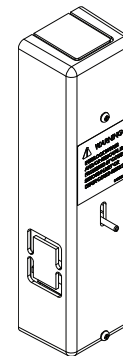



# Hoistway Specifications - Series F021 & F022

## ATTENTION CONSTRUCTION CONTRACTOR:

Job specific documentation for hoistway construction from Fox Valley Elevator will be provided to your local dealer.

**Hoistway Construction Requirements** to be completed prior to elevator installation by contractor.

### 1. Electrical Requirements By Others:

- Dedicated 230 VAC 60 Hertz 35 AMP Circuit Single Phase with ground and neutral,
- A fused lockable disconnect switch with branch 3 pole circuit wire to suit a 30 AMP service, fused for 30 AMP dual element (time delay fuse) with neutral.
- Dedicated 115 Volt, 15 AMP single phase circuit for car lighting and auxillary circuits.
- Electrical wiring to comply with applicable codes.
- Any VAC other than 230 VAC may require a buck/boost transformer.

#### NOTE :

Electrical requirements are for general reference only. All job specific electrical requirements must be acquired from job specific drawings provided by Fox Valley Elevator.

- 2. Unfinished/Un-installed Door** - Installation company may prefer a minimum of one hoistway door and associated framing be left unfinished/un-installed to accommodate elevator installation equipment and to prevent accidental damage to door and framing (preferably at grade level).
- 3. Plumb and Square Hoistway** - Hoistway must be plumb within 1/8 inch per 10 feet of height and square at any point within 1/4 inch based on difference in diagonal measurements.
- 4. Supportive Structure** - Structure must be capable of supporting the appropriate loads. Local engineering support is recommended.
- 5. Telephone Connection** - Code requires a telephone connection to the elevator car; therefore, a phone line must be installed leading to the controller. It must also be capable of working for 4 hours during a power outage.
- 6. ASME A17.1 Section 5.3** - Hoistway to be constructed in accordance with ASME A17.1 section 5.3 and all local codes.
- 7. Hoistway Door Security (Interlocks)** - All hoistway doors require interlocks as well as a door handle and a latch set. Interlocks will be installed by the elevator installers. Fox Valley Elevator requires the use of solid core doors and recommends spring door hinges.
- 8. Machinery Space, Machine Rooms, Control Spaces, and Control Rooms Layouts & Wiring** - All operating equipment must meet National Electrical Code and all local codes. Machine space must have a decicated convenience outlet and light with switch. The temperatures must be maintained between 60°- 110°F (15°C- 43°C) and must not be exposed to the elements with a max relative humidity of 90% (non-condensing).
- 9. No Alterations** - Any alterations to the equipment without written authorization by Fox Valley Elevator will void all warranties.
- 10. Pit Floor Strength** - A pit floor must be designed to withstand a load of 4,000 lbs. When used, concrete must be a minimum of 4" thick and rated at 3500 PSI.
- 11. Rated Load** - Elevator system is rated for maximum capacity from the factory. Flooring, trim, and/or permanent decor added to elevator car must be subtracted from car capacity.
- 12. Verify Code Requirements** - Verify national, state, and local code requirements are all met before installation.

# Machinery Spaces, Machine Rooms, Control Spaces, and Control Rooms Layouts & Wiring

(Series F021)

## Disconnect Power Before Wiring

- Locate controller enclosure in the machine room as required by code.
- Wire gauge requirements:
  - 10 gauge wire for power and motor wiring
  - 14 gauge minimum wire for lighting and aux circuits
  - 18 gauge wire for all low voltage**Note:** *Copper wire only.*
- Refer to unit specific schematics and field drawings to complete wiring. Wire per N.E.C. and local codes.

**Note:** Not all controller terminals or travel cable wires may be used. High voltage and low voltage wires must run separate and only cross over perpendicular to each other.

- Locate and check for correct fuse sizes.

### Per NEC Code 110.26 .....

Clear Working Space. The working space required by this section must be clear at all times. **Therefore, this space isn't permitted for storage.** When normally enclosed live parts are exposed for inspection or servicing, the working space, if in a passageway or general open space, must be suitably guarded.

Working Space. Equipment that may need examination, adjustment, servicing, or maintenance while energized must have working space provided in accordance with (1), (2), and (3):

1. Depth of Working Space. The working space, which is measured from the enclosure front, must not be less than the distance of 36".
2. Width of Working Space. The width of the working space must be a minimum of 30", but in no case less than the width of the equipment.

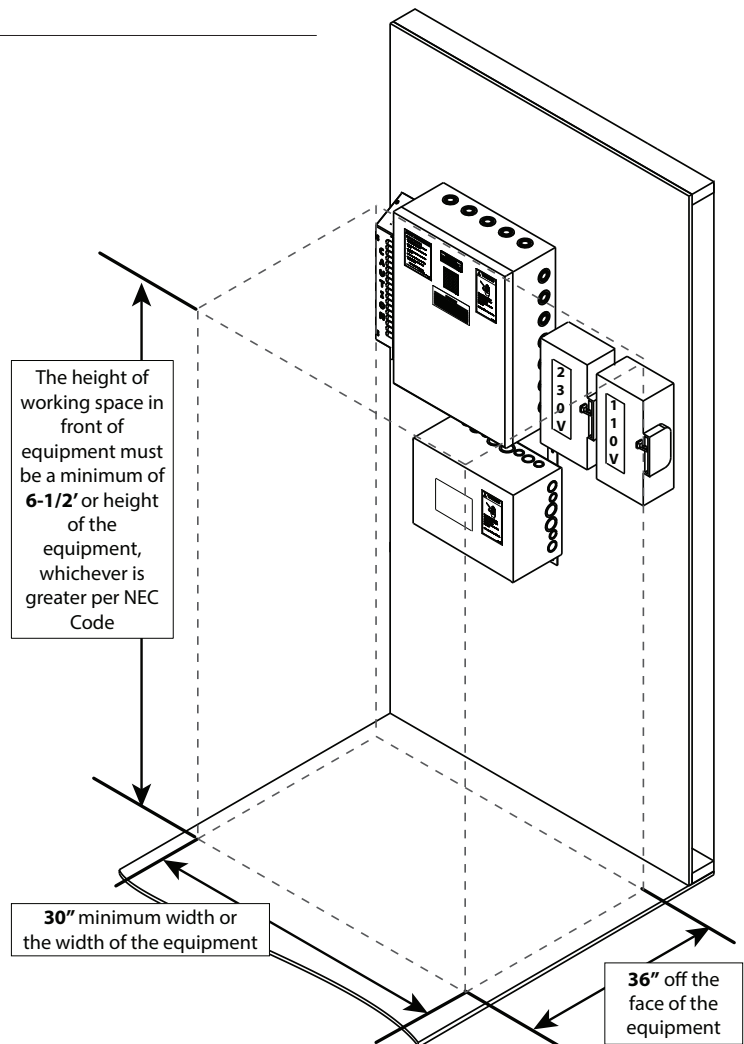

# Machinery Spaces, Machine Rooms, Control Spaces, and Control Rooms Layouts & Wiring

(Series F021)

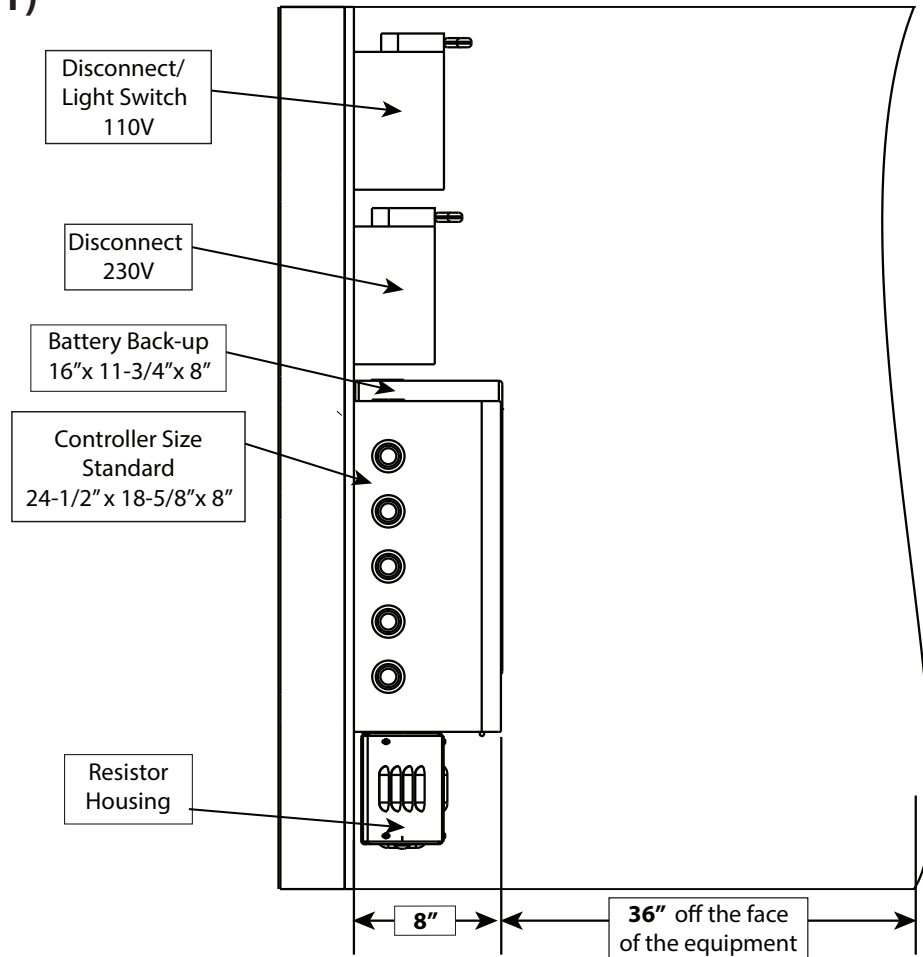

## Per NEC Code 110.26 Continued .....

3. Height of Working Space (Headroom). The height of the working space in front of equipment must not be less than 6½' or the height of the equipment measured from the floor, grade or platform, whichever is greater.

Other equipment must not extend more than 6" into the controller working space.

## Additional Notes

- A lockable service disconnect must be placed within sight of the controller and must be easily accessible in case of an emergency.
- Machine room and controller space must contain a convenience outlet and light with switch.
- The temperatures must be maintained between 60°- 110°F (15°C- 43°C) and must not be exposed to the elements with a max relative humidity of 90% (non-condensing).
- The frequency drive may be heard running for thermal heat dissipation at any time.

# Machinery Spaces, Machine Rooms, Control Spaces, and Control Rooms Layouts & Wiring

(Series F022)

## Disconnect Power Before Wiring

- Locate controller enclosure in the machine room as required by code.
- Wire gauge requirements:
  - 10 gauge wire for power and motor wiring
  - 14 gauge minimum wire for lighting and aux circuits
  - 18 gauge wire for all low voltage**Note:** *Copper wire only.*
- Refer to unit specific schematics and field drawings to complete wiring. Wire per N.E.C. and local codes.

**Note:** Not all controller terminals or travel cable wires may be used. High voltage and low voltage wires must run separate and only cross over perpendicular to each other.

- Locate and check for correct fuse sizes.

## Per NEC Code 110.26 .....

Clear Working Space. The working space required by this section must be clear at all times. **Therefore, this space isn't permitted for storage.** When normally enclosed live parts are exposed for inspection or servicing, the working space, if in a passageway or general open space, must be suitably guarded.

Working Space. Equipment that may need examination, adjustment, servicing, or maintenance while energized must have working space provided in accordance with (1), (2), and (3):

1. Depth of Working Space. The working space, which is measured from the enclosure front, must not be less than the distance of 36".
2. Width of Working Space. The width of the working space must be a minimum of 30", but in no case less than the width of the equipment.

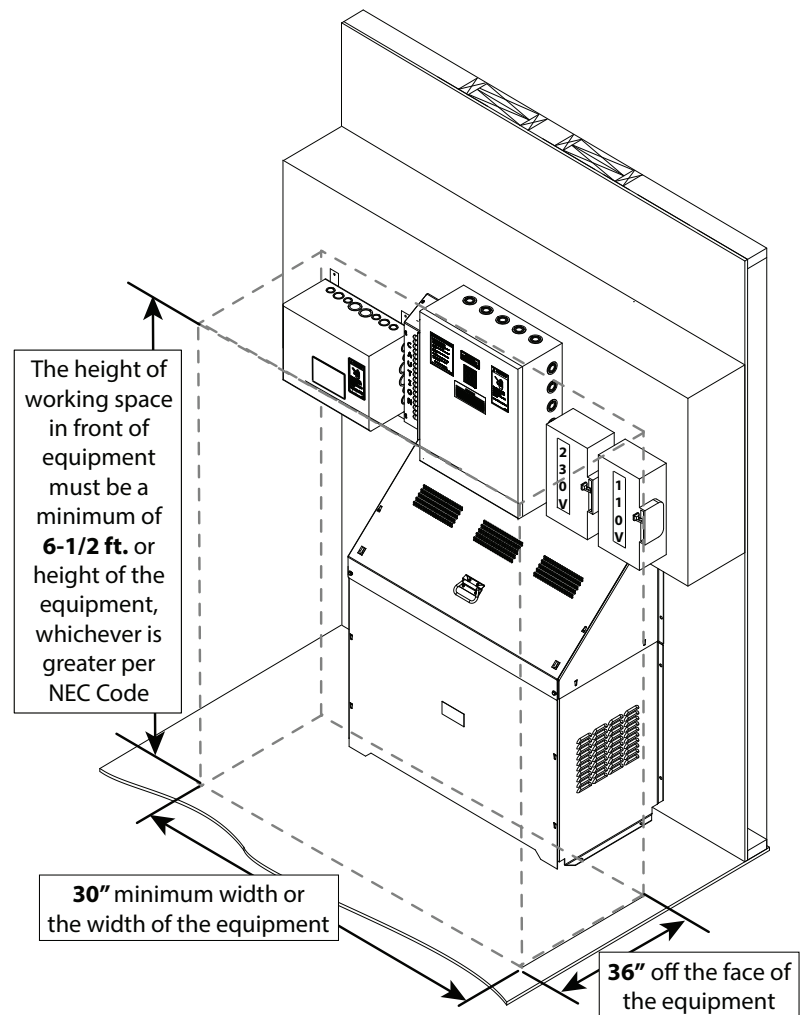

# Machinery Spaces, Machine Rooms, Control Spaces, and Control Rooms Layouts & Wiring

(Series F022)

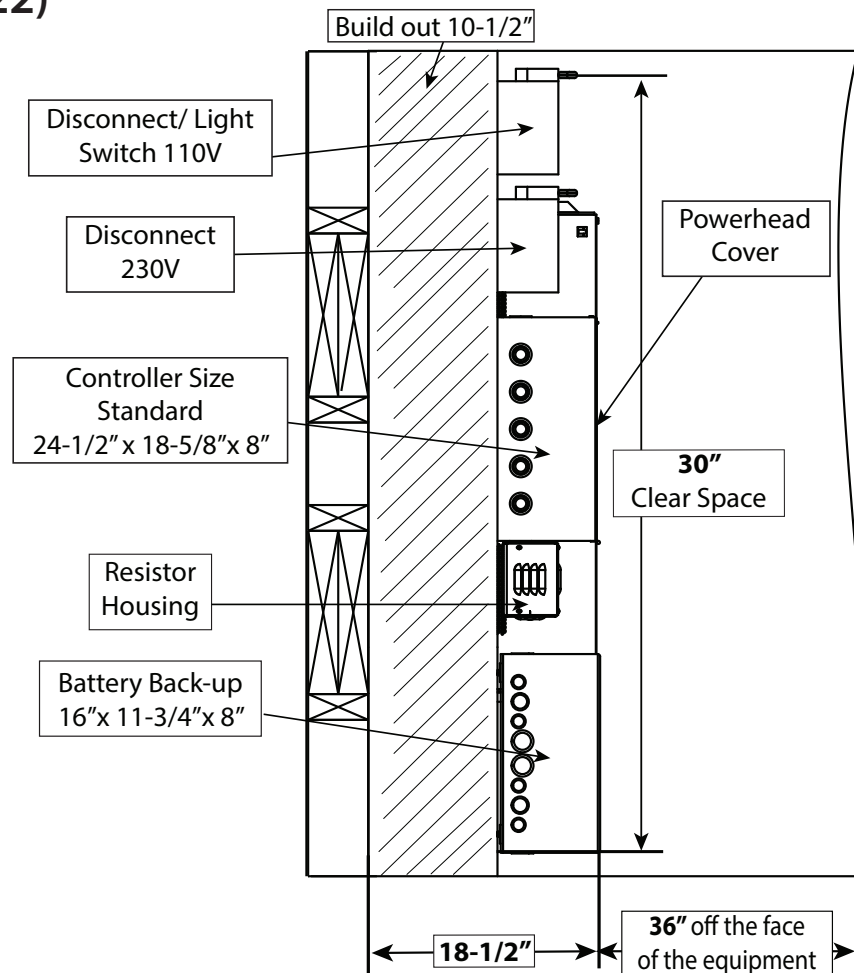

## Per NEC Code 110.26 Continued .....

3. Height of Working Space (Headroom). The height of the working space in front of equipment must not be less than 6½' or the height of the equipment measured from the floor, grade or platform, whichever is greater.

Other equipment must not extend more than 6" into the controller working space.

## Additional Notes

- A lockable service disconnect must be placed within sight of the controller and must be easily accessible in case of an emergency.
- Machine room and controller space must contain a convenience outlet and light with switch.
- The temperatures must be maintained between 60°- 110°F (15°C- 43°C) and must not be exposed to the elements with a max relative humidity of 90% (non-condensing).
- The frequency drive may be heard running for thermal heat dissipation at any time.

# Machinery Spaces, Machine Rooms, Control Spaces, and Control Rooms Layouts & Wiring

(Series F022)

Travel (Feet)	<22	<36	<50
Drum Length (Inch)	12	18	24
Starting Wraps on Drum	2	2	2

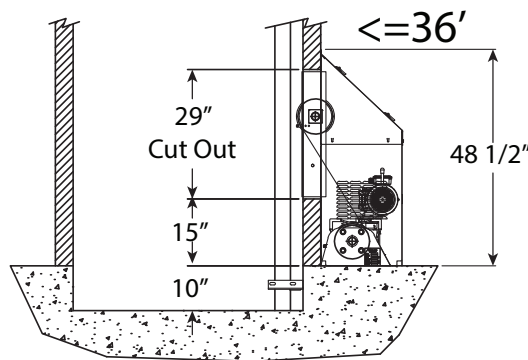
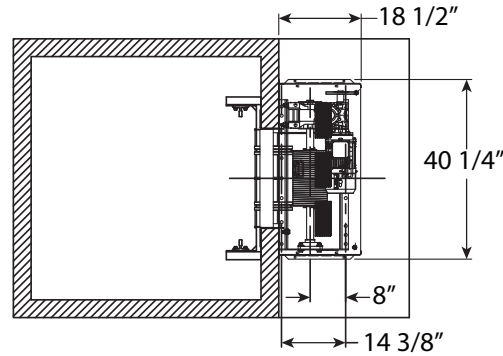

36' < 50' Cover is 3" wider.

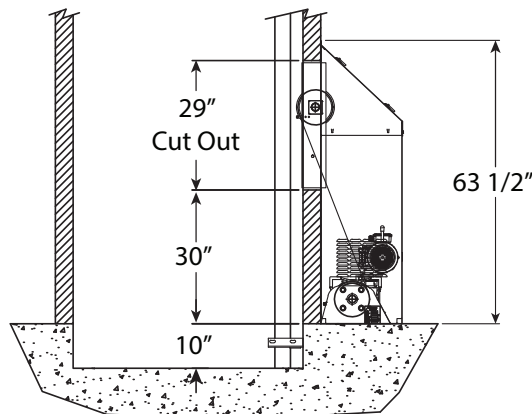

This layout applies to first floor machine room only.  
 Layouts may change depending on which floor contains the machine room.  
 Contact Fox Valley Elevator for more information.

# Example Hoistway Construction - Series F021 & F022

Typical layouts shown here may vary from your actual hoistway.

The purpose of these layouts is for a general understanding.

Please refer to the Fox Valley Elevator drawings and specifications that will be provided by your local dealer.

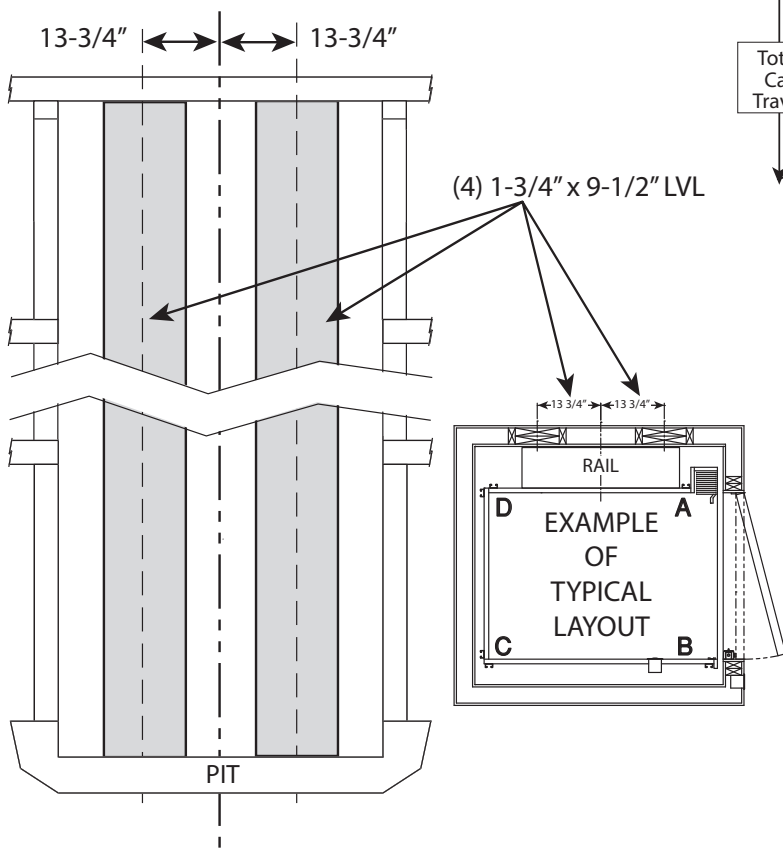
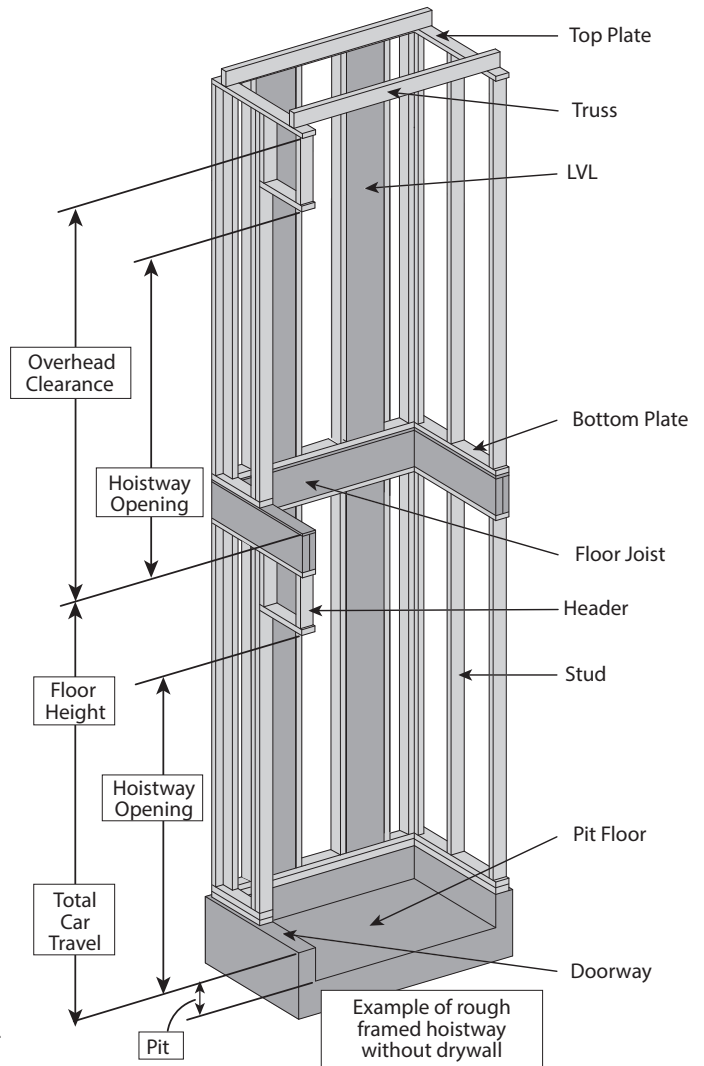

**These drawings depict sample construction only. It is the responsibility of the installer/contractor or engineer to design and specify structural supports. All construction to be in compliance with local codes.**

# Hoistway Elevation View with T-Rail - Series F021

- Structure is required to support lifting device for powerhead installation. Locate near center of shaft (by others) minimum rating for 1,000 lbs. Additional space may be required for hoisting and maneuvering equipment into place.
- Access Door required by powerhead.
- Additional disconnect required at top of elevator hoistway by motor of the powerhead per NEC Code 430.102 (B) (1).
- Fox Valley Elevator's Excelevator Series offers a total of six stops and a total travel distance of 50 feet.

## Required Overhead Heights

Inside Cab Dimension	6' 10"	7' 0"	7' 4"	8' 0"
Minimum Hoistway Overhead Height	9' 0"	9' 2"	9' 6"	10' 2"

Cab Height - 6' min.

\*Custom sized cabs will alter these dimensions. Fox Valley Elevator will provide you with the appropriate dimensions. Please contact your local dealer to acquire alternate layouts.

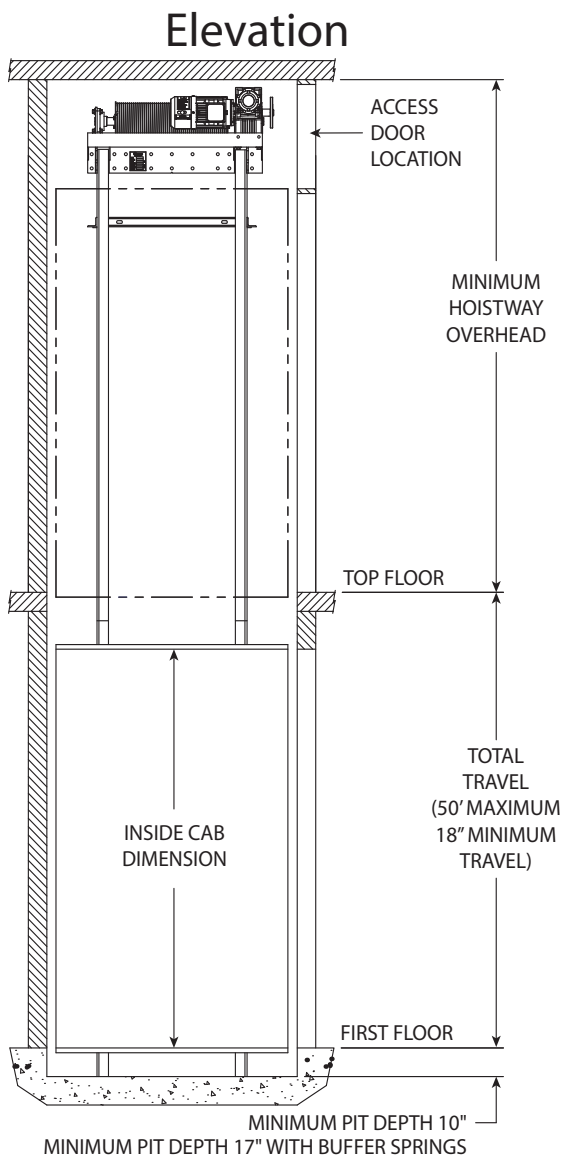

Note:  
Controller to be located outside of hoistway.

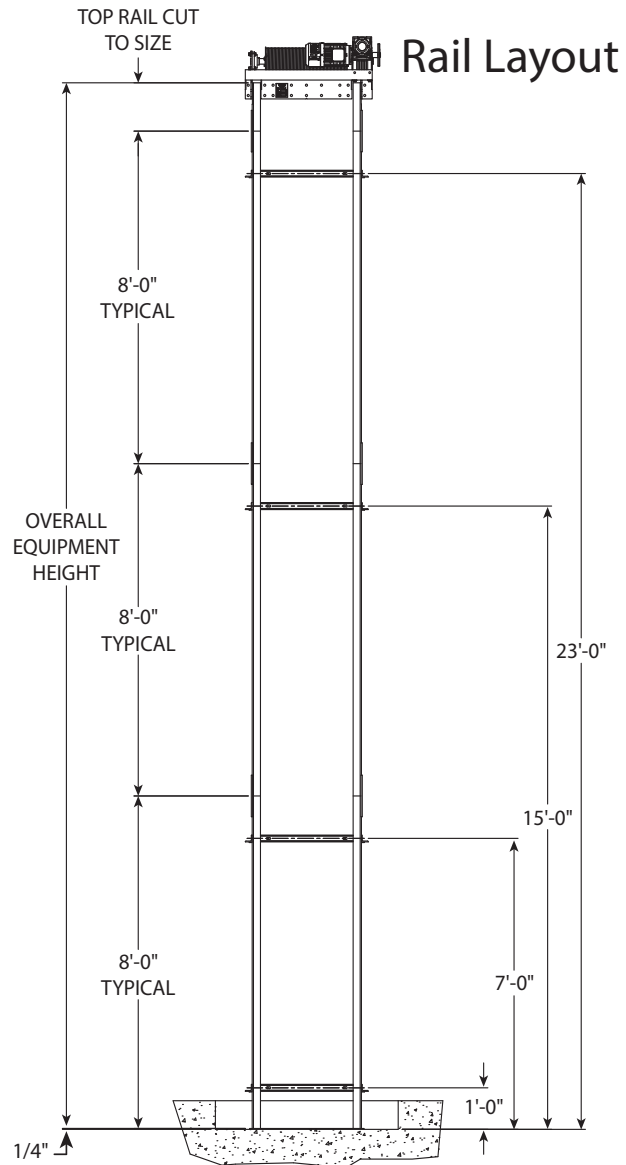

## Rail Calculations

Rail Length =  
Pit Depth + Travel + Car I.D. Height + 12"



# Hoistway Elevation View with T-Rail - Series F022

## Required Overhead Heights

Inside Cab Dimension	6' 10"	7' 0"	7' 4"	8' 0"
Minimum Hoistway Overhead Height	7' 10"	8' 0"	8' 4"	9' 0"

\*Custom sized cabs will alter these dimensions. Fox Valley Elevator will provide you with the appropriate dimensions. Please contact your local dealer to acquire alternate layouts.

Cab Height - 6' min.

Fox Valley Elevator's Excelelevator Series offers a total of six stops and a total travel distance of 50 feet.

### Elevation

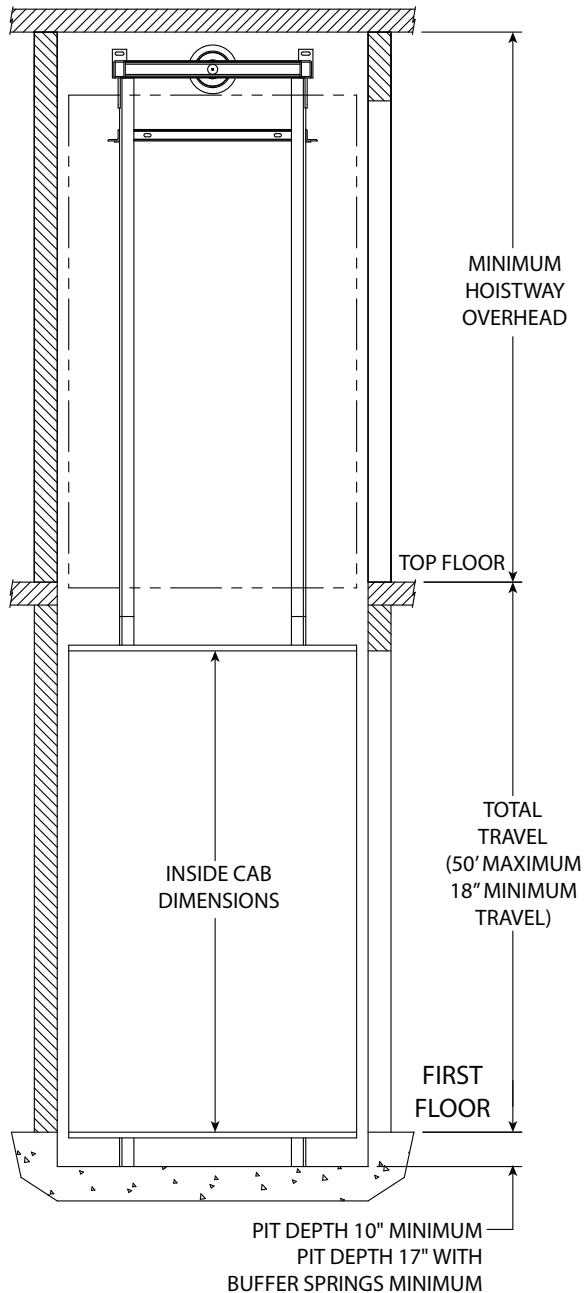

### Rail Layout

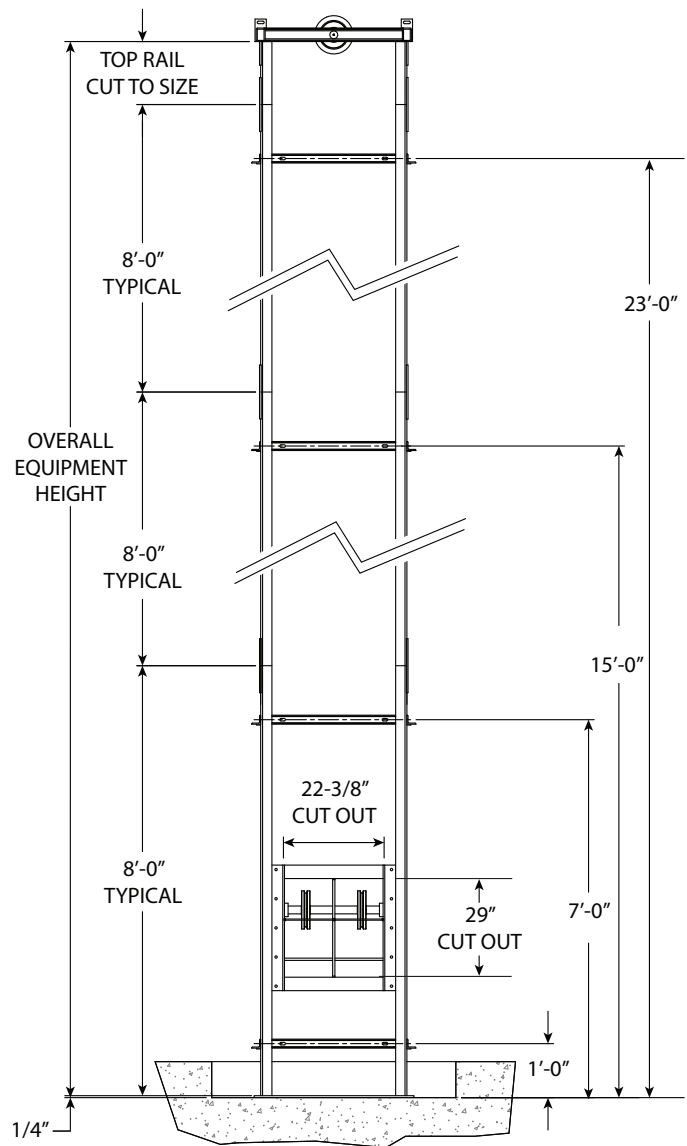

### Rail Calculations

Rail Length =  
Pit Depth + Travel + Car I.D. Height + 4"

# Example Hoistway Layouts - Series F021 & F022

## Minimum and Maximum Dimensions

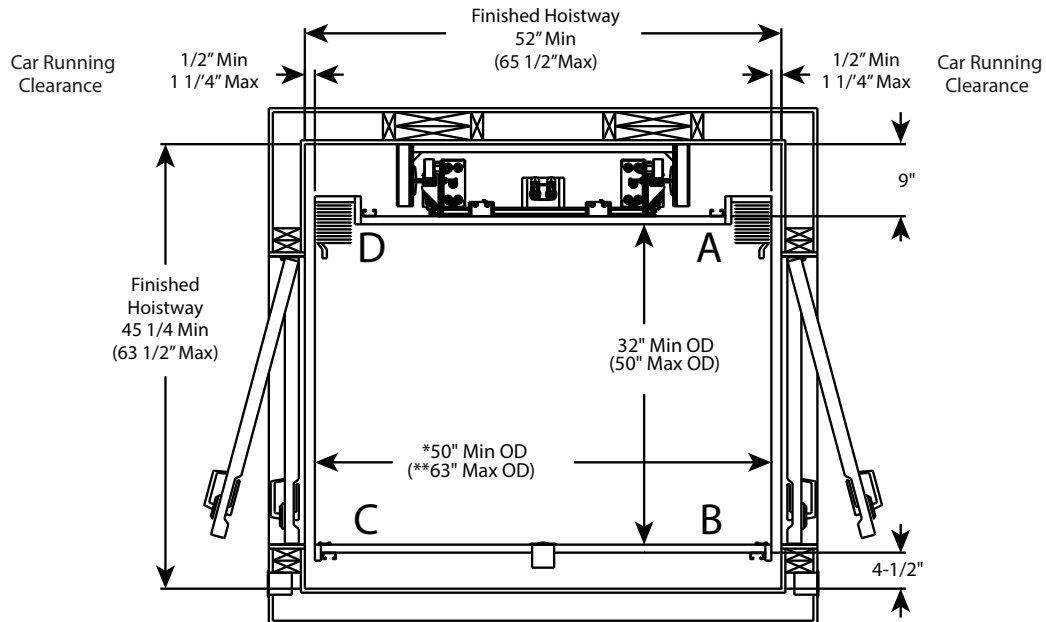

\* Single Opening - 43-1/4" OD (Outside dimension) **minimum** (Rail may not be centered in hoistway)

\*\* Single Opening - 62 - 1/2" OD (Outside dimensions) **maximum**

### Note:

1. Minimum DA dimensions reflect rail centered in hoistway.
2. Minimum DA dimension for car without a gate recess is 37" OD (outside dimension)  
Car ID (inside dimensions) can not exceed 15 sq. ft. for 1,000 lb.

## Car Opening Configurations and Coding

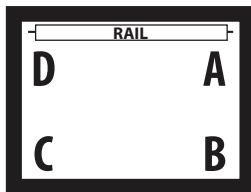
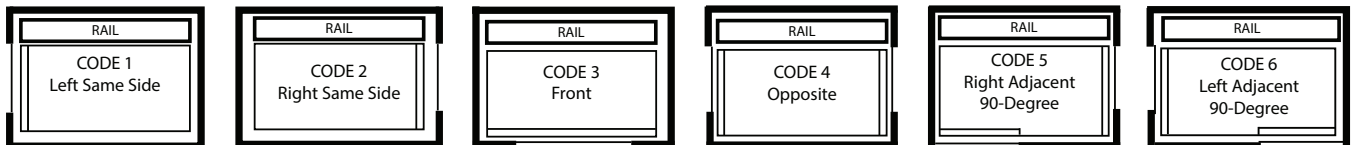

1. The DA is the side on which the rail is attached.
2. The first letter refers to the attachment location of the gate.
3. The second letter refers to the location of the strike plate.
4. If present, the third letter "R" denotes a recessed gate.

### Example

#### First Gate - ABR

A- gate attachment  
B - strike plate  
R - recessed gate

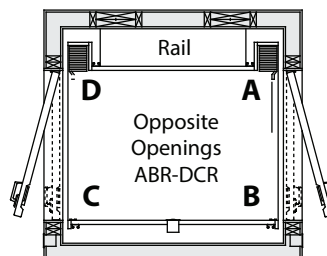

#### Second Gate - DCR

D - gate attachment  
C - strike plate  
R - recessed gate

# Example Hoistway Layouts - Series F021 & F022

## Construction Notes:

- Use specified rail backing from architect to frame into wall. Fox Valley Elevator recommends LVL's.
- The hoistway illustrations below show finished dimensions. Finished hoistway dimensions include drywall, plaster, and paint.
- A maximum of 3/4" (see "f" below) are allowed between the closed hoistway door and the outer edge of the landing sill.
- Determine height of hall station by local code.
- Rough frame door in place with extra space as needed for door interlock system, reference national and local codes.

The following examples are of units up to 1,000 lbs. Elevators are illustrated with accordion gates. The following layouts were designed for travel up to 50 feet.

These symbols are listed beside the car size Fox Valley Elevator believes to be best suited for use by wheelchair passengers and their accompanying attendant.



Recommended size for wheelchair passenger



Recommended size for both wheelchair and attendant passengers

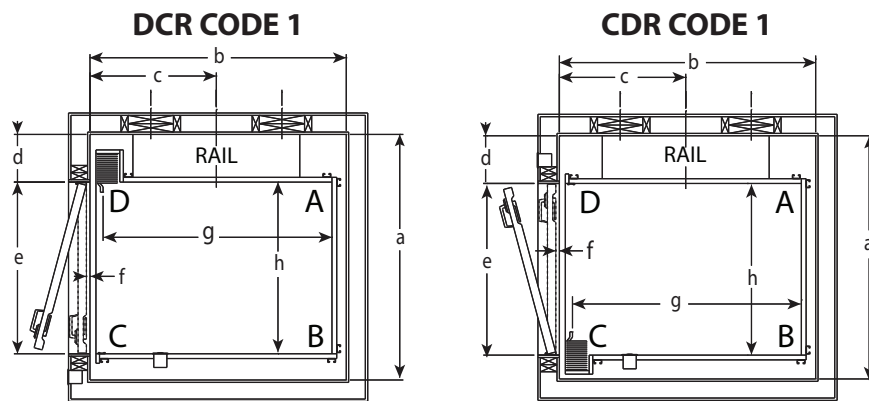

Hoistway Layout	Platform Area ID	Car Size	a	b	c	d	e	f	g	h
DCR Code 1	12 sq ft	48" X 36"	51"	54.75"	26.5"	10"	36"	0.75"	48"	36"
	15 sq ft	54" X 40"	55"	60.75"	29.5"	14"	36"	0.75"	54"	40"
	15 sq ft	60" X 36"	51"	66.75"	32.5"	10"	36"	0.75"	60"	36"
CDR Code 1	12 sq ft	48" X 36"	52.5"	54.75"	26.5"	10"	36"	0.75"	48"	36"
	15 sq ft	54" X 40"	55"	60.75"	29.5"	10"	36"	0.75"	54"	40"
	15 sq ft	60" X 36"	52.5"	66.75"	32.5"	10"	36"	0.75"	60"	36"

\*All dimensions are finished hoistway dimensions

# Example Hoistway Layouts - Series F021 & F022

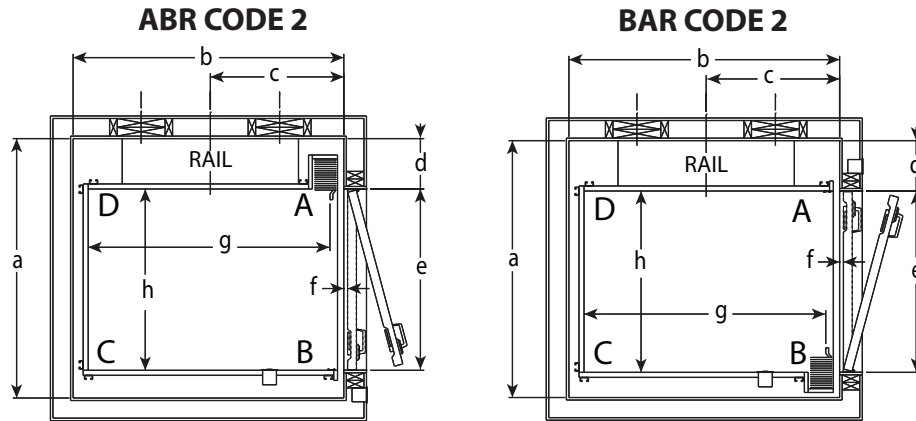

Hoistway Layout	Platform Area ID	Car Size	a	b	c	d	e	f	g	h
ABR Code 2	12 sq ft	48" X 36"	51"	54.75"	26.5"	10"	36"	0.75"	48"	36"
	15 sq ft	54" X 40"	55"	60.75"	29.5"	14"	36"	0.75"	54"	40"
	15 sq ft	60" X 36"	51"	66.75"	32.5"	10"	36"	0.75"	60"	36"
BAR Code 2	12 sq ft	48" X 36"	52.5"	54.75"	26.5"	10"	36"	0.75"	48"	36"
	15 sq ft	54" X 40"	55"	60.75"	29.5"	10"	36"	0.75"	54"	40"
	15 sq ft	60" X 36"	52.5"	66.75"	32.5"	10"	36"	0.75"	60"	36"

\*All dimensions are finished hoistway dimensions

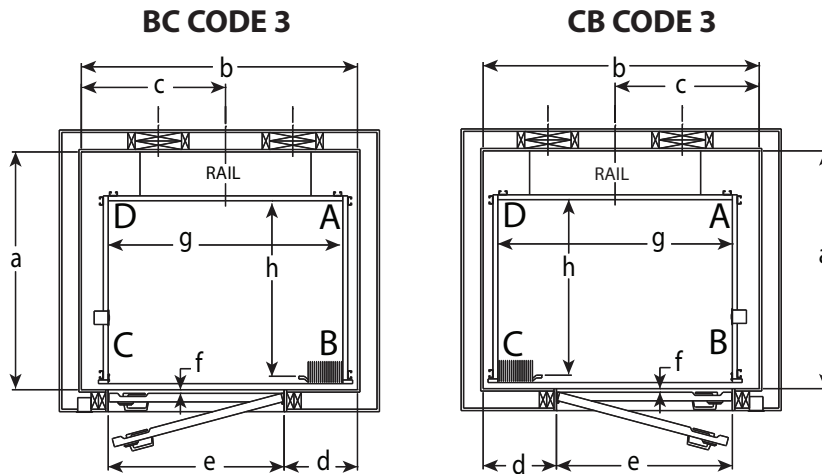

Hoistway Layout	Platform Area ID	Car Size	a	b	c	d	e	f	g	h
BC Code 3	12 sq ft	48" X 36"	48.75"	57"	29"	16"	36"	0.75"	48"	36"
	15 sq ft	54" X 40"	52.75"	63"	32"	22"	36"	0.75"	54"	40"
	15 sq ft	60" X 36"	48.75"	69"	35"	28"	36"	0.75"	60"	36"
CB Code 3	12 sq ft	48" X 36"	48.75"	57"	29"	16"	36"	0.75"	48"	36"
	15 sq ft	54" X 40"	52.75"	63"	32"	22"	36"	0.75"	54"	40"
	15 sq ft	60" X 36"	48.75"	69"	35"	28"	36"	0.75"	60"	36"

\*All dimensions are finished hoistway dimensions

# Example Hoistway Layouts - Series F021 & F022

**ABR - DCR CODE 4**

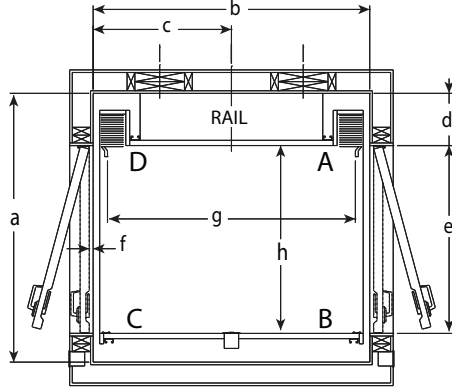

**BAR - DCR CODE 4**

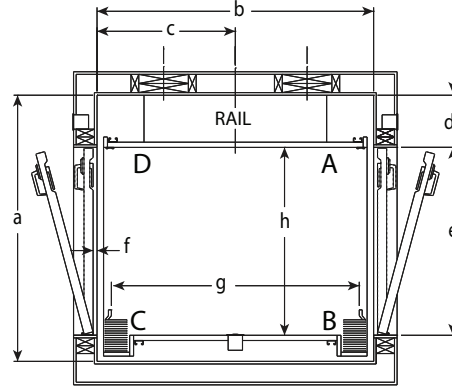

Hoistway Layout	Platform Area ID	Car Size	a	b	c	d	e	f	g	h
ABR - DCR Code 4	12 sq ft	48" X 36"	51"	53.5"	26.75"	10"	36"	0.75"	48"	36"
	15 sq ft	54" X 40"	55"	59.5"	29.75"	14"	36"	0.75"	54"	40"
	15 sq ft	60" X 36"	51"	65.5"	32.75"	10"	36"	0.75"	60"	36"
BAR - CDR Code 4	12 sq ft	48" X 36"	52.5"	53.5"	26.75"	10"	36"	0.75"	48"	36"
	15 sq ft	54" X 40"	55"	59.5"	29.75"	10"	36"	0.75"	54"	40"
	15 sq ft	60" X 36"	52.5"	65.5"	32.75"	10"	36"	0.75"	60"	36"

\*All dimensions are finished hoistway dimensions

**ABR - BC CODE 5**

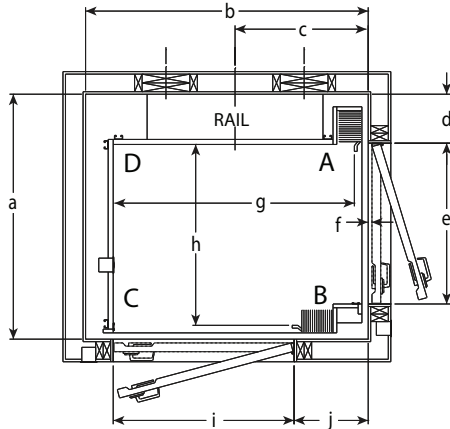

**DCR - CB CODE 6**

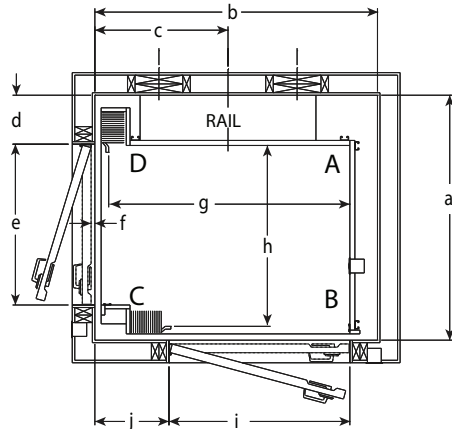

Hoistway Layout	Platform Area ID	Car Size	a	b	c	d	e	f	g	h	i	j
ABR-BC Code 5	12 sq ft	48" X 36"	48.75"	55.75"	26.5"	9.75"	32"	0.75"	48"	36"	36"	14.75"
	15 sq ft	54" X 40"	52.75"	61.75"	29.5"	9.75"	36"	0.75"	54"	40"	36"	20.75"
	15 sq ft	60" X 36"	48.75"	67.75"	32.5"	9.75"	32"	0.75"	60"	36"	36"	26.75"
DCR-CB Code 6	12 sq ft	48" X 36"	48.75"	55.75"	26.5"	9.75"	32"	0.75"	48"	36"	36"	14.75"
	15 sq ft	54" X 40"	52.75"	61.75"	29.5"	9.75"	36"	0.75"	54"	40"	36"	20.75"
	15 sq ft	60" X 36"	48.75"	67.75"	32.5"	9.75"	32"	0.75"	60"	36"	36"	26.75"

\*All dimensions are finished hoistway dimensions





# FOX VALLEY ELEVATOR™

IS A PROUD MEMBER OF



Canadian Elevator  
Contractors Association

Fox Valley Elevator, LLC is a proud member of The American Society of Mechanical Engineers, The National Association of Elevator Contractors, The Canadian Elevator Contractors Association and The Accessibility Equipment Manufacturers Association. These organizations assure you of our commitment to high quality and accessibility to everyone.



**800-238-8739**  
foxvalleyelevator.com  
1726 North Ballard Road • Suite 1  
Appleton, WI 54911  
Info@foxvalleyelevator.com



**MADE IN THE USA**



with US and Global Parts